

(12) UK Patent Application

(19) GB (11) 2 256 023 (13) A

(43) Date of A publication 25.11.1992

<p>(21) Application No 9110787.0</p> <p>(22) Date of filing 18.05.1991</p>	<p>(51) INT CL⁵ F16B 5/00</p>
<p>(71) Applicant Magnet Holdings Limited (Incorporated in the United Kingdom) Royd Ings Avenue, Keighley, West Yorkshire, BD21 4BY, United Kingdom</p> <p>(72) Inventor David Stephen Baker</p> <p>(74) Agent and/or Address for Service Audrey Knowles & Co 624 Pershore Road, Selly Park, Birmingham, B29 7HG, United Kingdom</p>	<p>(52) UK CL (Edition K) F2M MC2 M201 M209 M234 M244 M274 U1S S1706 S1714</p> <p>(56) Documents cited GB 1430423 A GB 1275511 A GB 1237744 A GB 1127915 A EP 0248127 A US 3526420 A</p> <p>(58) Field of search UK CL (Edition K) F2M INT CL⁵ F16B Online databases: WPI</p>

(54) Joint

(57) A joint between the adjoining side edges of two similar panels, 1, 1' in which one panel 1 has a channel-section recess 9 open towards the front face 3 and the other panel 1' has a rib 10 facing towards the rear face 4 for reception in the recess 9 to restrict separation of the panels 1, 1' to provide a predetermined expansion gap between the adjacent side edges. The panels may be tongue (5) and groove (6) boards in the construction of a door.

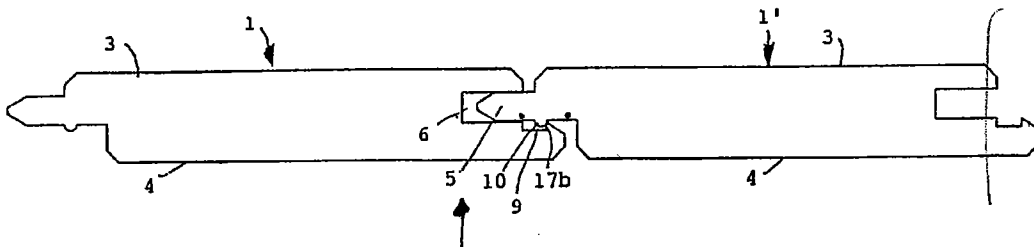

FIGURE 5.

⑩ 102b

⑫ 103a need both laminate flooring structure.

GB 2 256 023 A

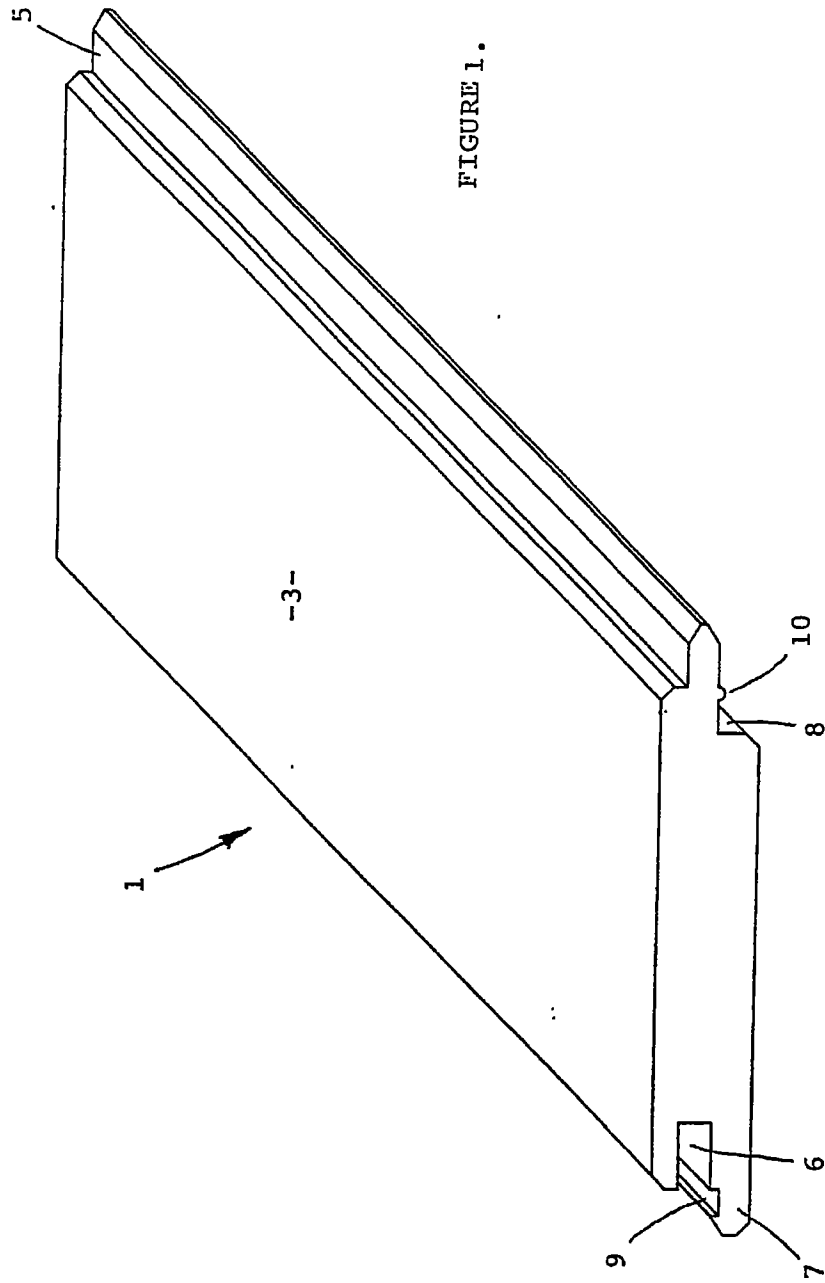

FIGURE 1.

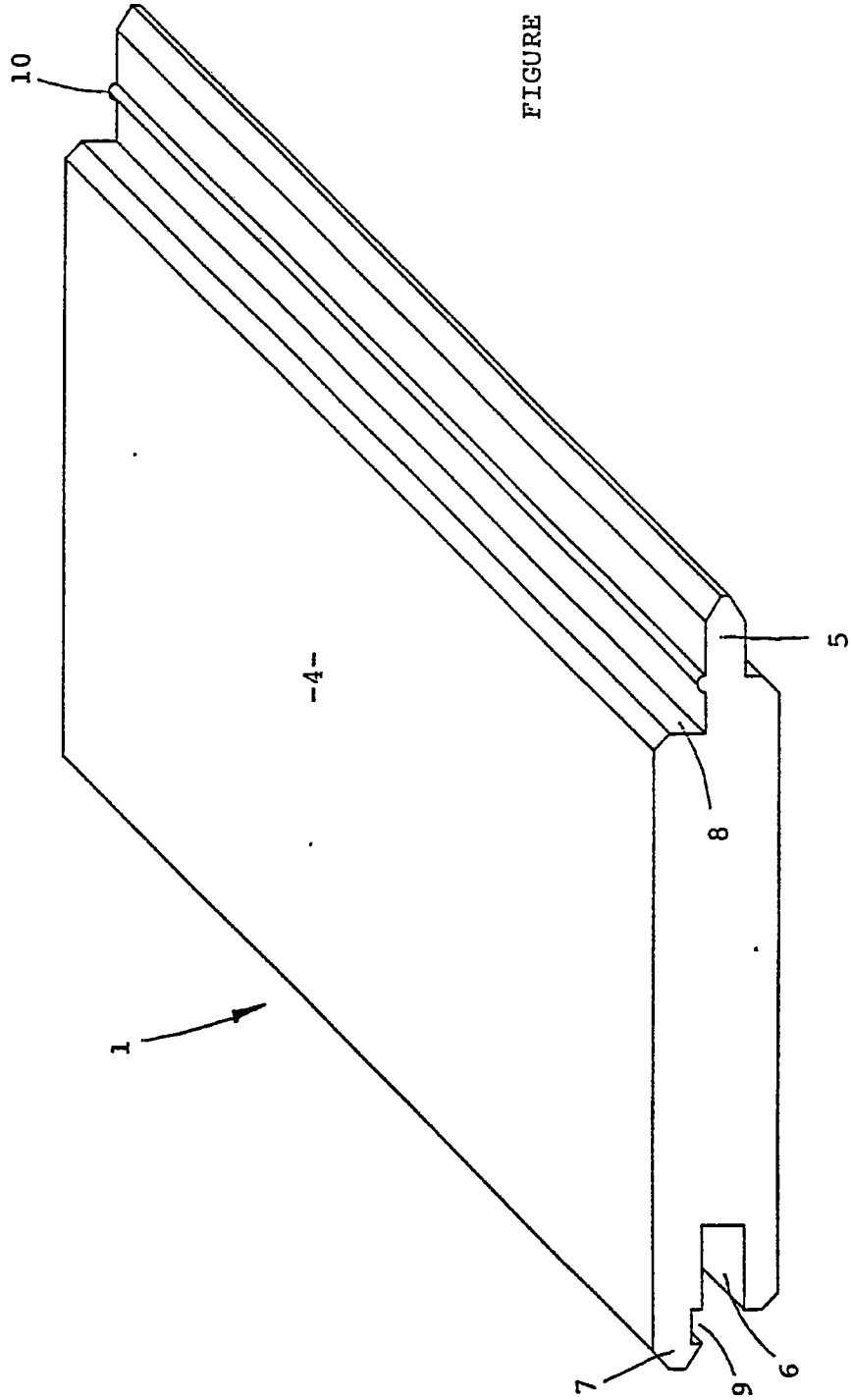

FIGURE 2.

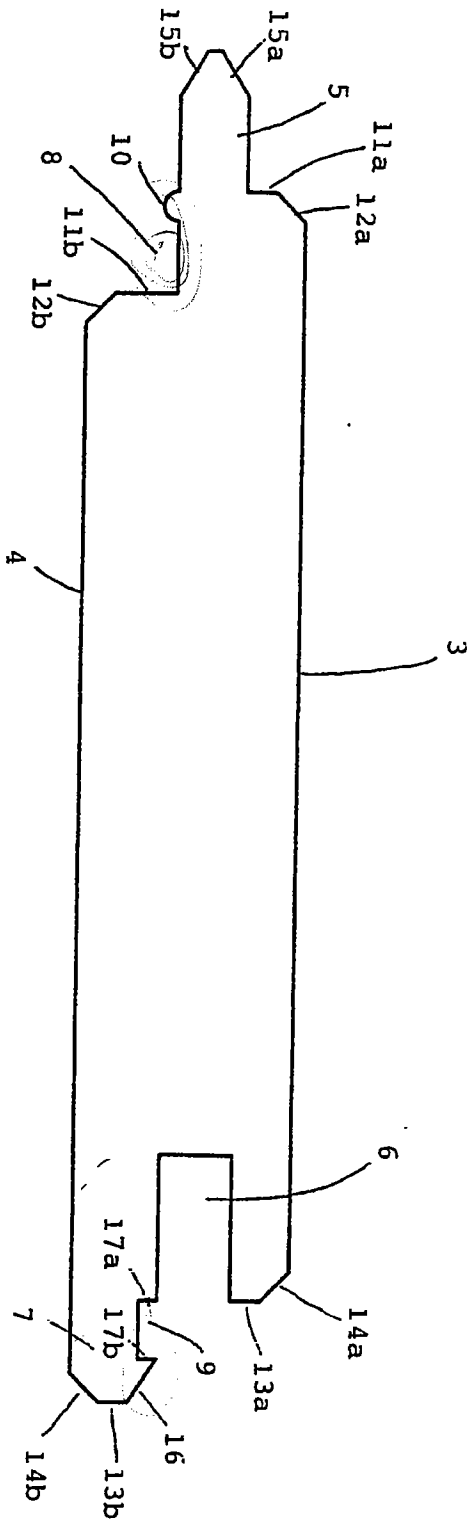

FIGURE 3

4:7

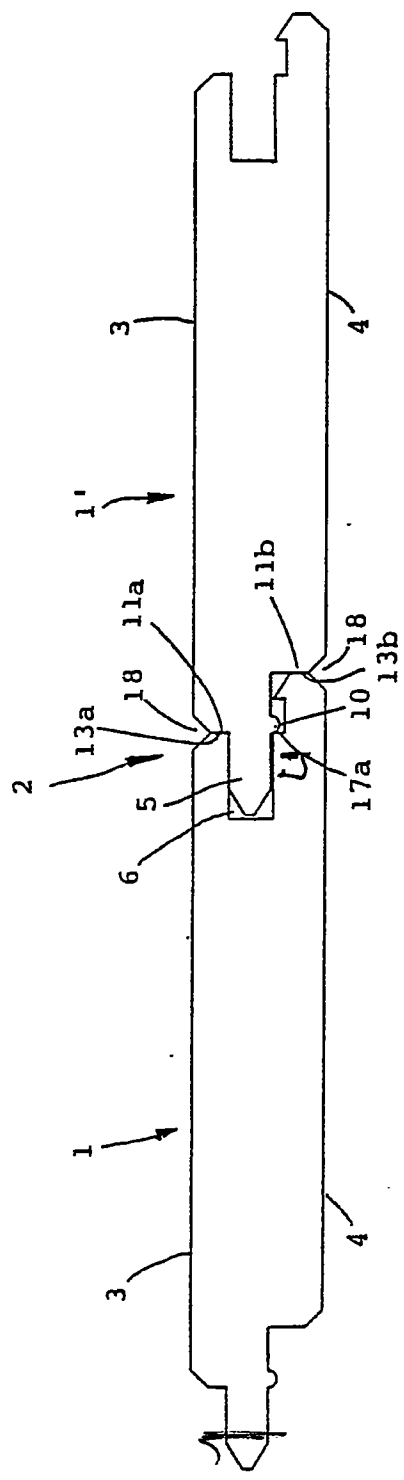

FIGURE 4.

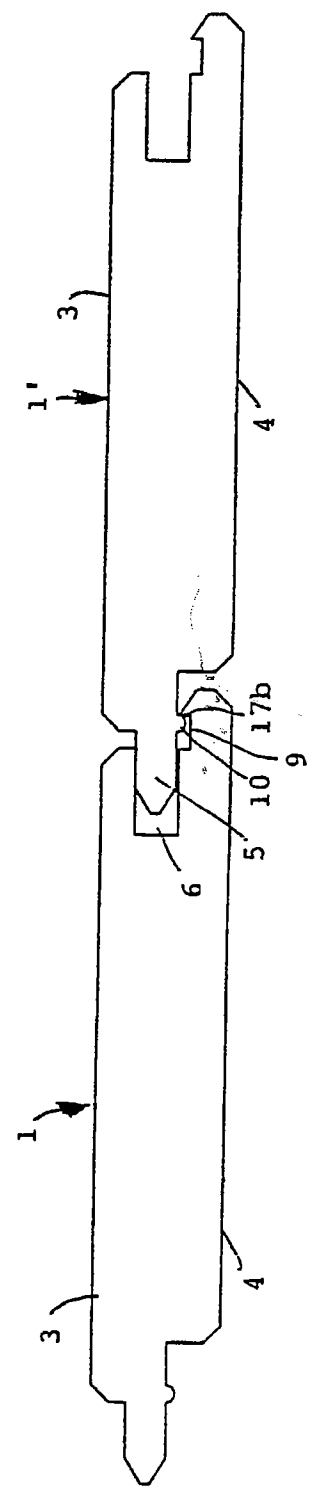

FIGURE 5.

5:7

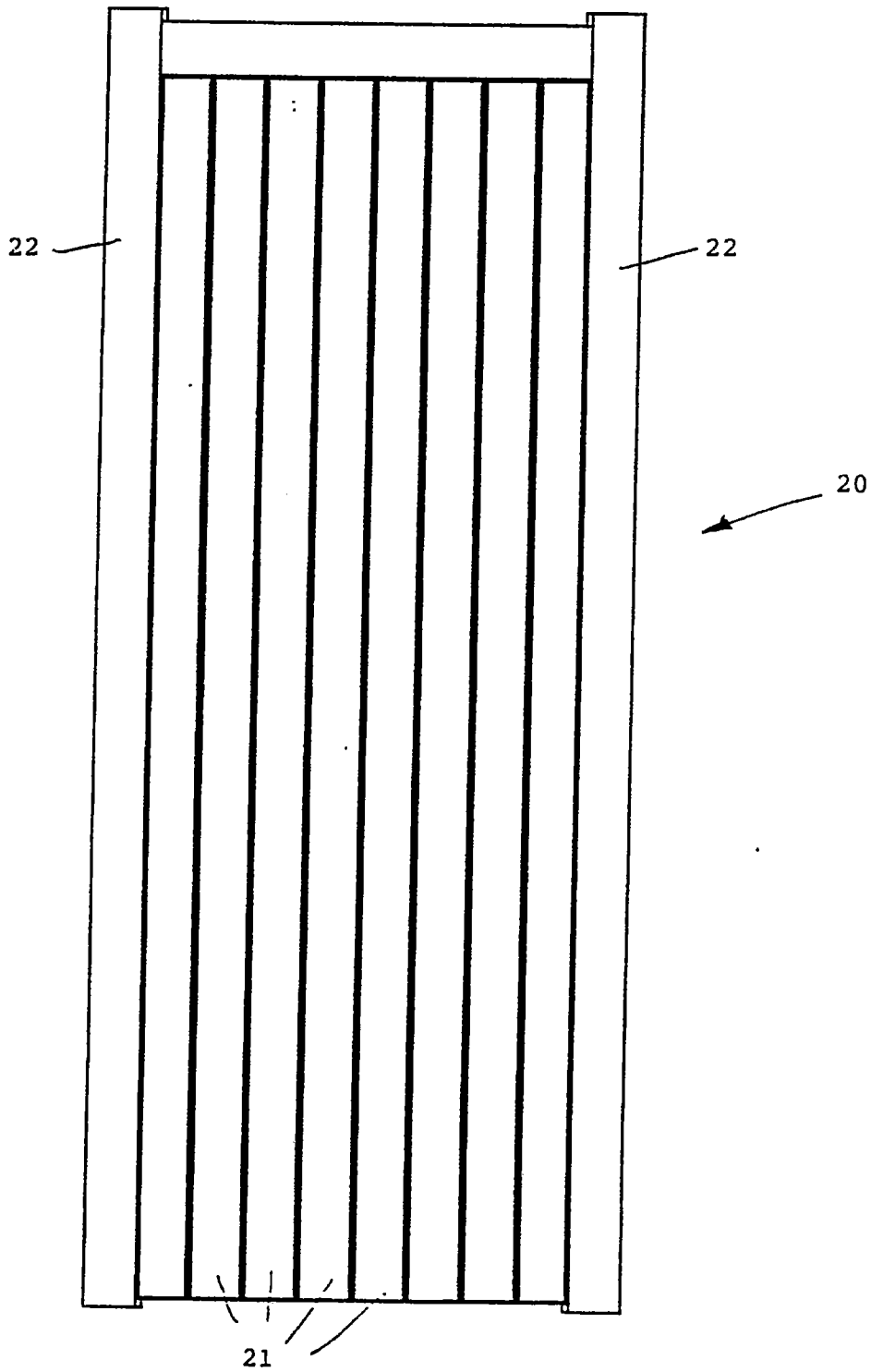

FIGURE 6

6:7

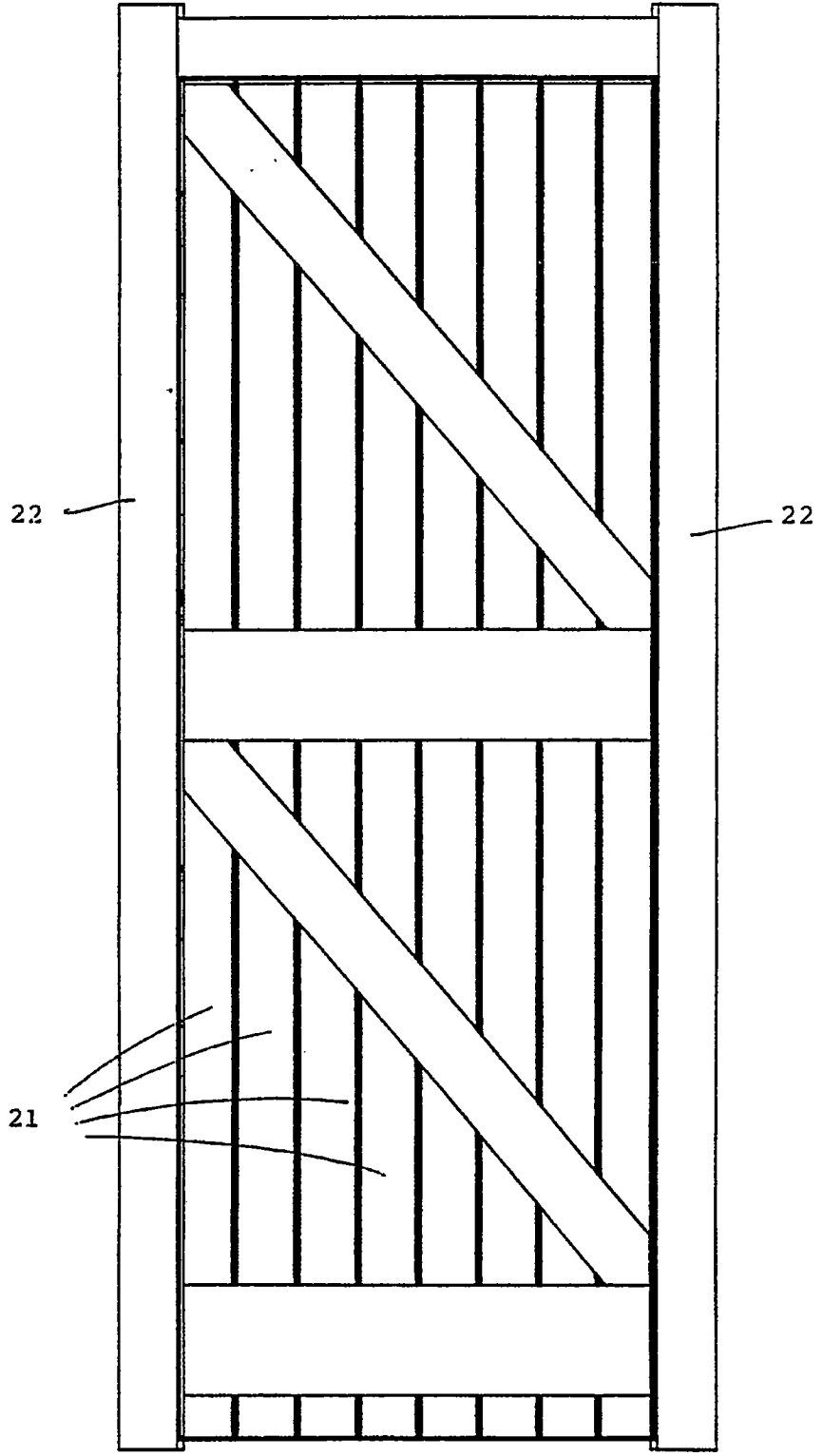

FIGURE 7.

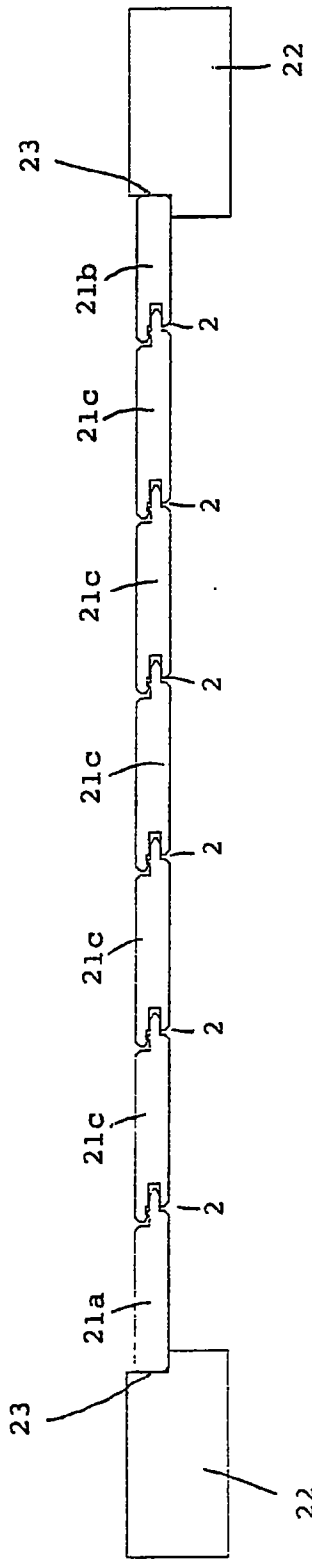

FIGURE 8.

7:7

JOINT

This invention relates to an improved joint between the adjoining side edges of two panels and to a panel for assembly with an adjoining panel to produce such joint.

It is well known to provide a tongue and groove joint between the adjoining side edges of two panels such as wooden panels used for flooring, cladding and the like.

The known panels have a tongue on one side edge and a complementary groove on the opposed side edge such that similar panels can be assembled by inserting the tongue of one panel into the groove of the adjoining panel.

Usually, the tongue is inserted fully into the groove so that the side edges of the panels abut one another to support the panels against deflection.

A problem arises, however, where wooden panels are exposed to moisture, for example when used to construct external doors or during building work, as the panels swell causing the butted side edges of the panels to deform creating a ridge in the front surface.

It has already been proposed to allow for swelling of the panels by making the tongue slightly longer than the groove is deep so that, when the tongue is inserted fully into the groove, the side edges of the panels are slightly spaced apart.

This solution is not entirely satisfactory, however, in that swelling of the panels still creates deforming forces between the panels through the engagement of the tip of the tongue with the base of the groove.

It is an object of the present invention to provide an improved joint and a panel for use in forming the joint which mitigates the problems of the known joints and panels.

According to one aspect of the invention we provide a joint between adjoining side edges of two panels wherein the side edges have co-operating formations adapted to restrict separation of the panels to provide a pre-determined spacing between the side edges in the assembled joint.

Preferably, the panels have front and rear faces and the co-operating formations are provided between the front and rear faces. ^a

Conveniently, the co-operating formations comprise a longitudinal recess on one panel that is open towards one of said faces and a longitudinal rib on the other panel that faces towards the other of said faces for reception in the recess in the assembled joint. ¹⁰

With this arrangement, the rib ¹⁰ is engageable with one side edge of the recess ^a to restrict separation of the panels to provide the pre-determined spacing between the side edges of the panels in the assembled joint.

The rib may be engageable with the opposed side edge of the recess when the side edges of the panel abut one another or this engagement may provide a pre-determined minimum spacing between the side edges of the panel in the assembled joint.

Advantageously, one of the rib and recess is provided on a projection on the side edge of one panel and the other of the rib and recess is provided in a rebate on the side edge of the other panel in which the projection is received in the assembled joint.

9+10
could
be
reversed

Preferably, the joint includes a tongue on the side edge of one panel that is received in a groove on the adjoining side edge of the other panel whereby the panels are interlocked to resist deflection in a direction normal to the front and rear faces.

Advantageously, the tip of the tongue is of reduced cross-section, for example the tip may have opposed chamfer faces. In this way, the panels may be tilted relative to each other with the tongue partially engaged in the groove for locating the rib in the recess when assembling the joint.

Tilting

According to another aspect of the invention we provide first and second panels for assembly along adjoining side edges to form the joint according to the first aspect of the invention.

Preferably, the first and second panels are similar having the co-operating formations on opposed side edges.

According to yet another aspect of the invention we provide a panel having co-operating formations on the opposed side edges constructed and arranged such that when the panel is joined to a similar panel along adjoining side edges, the co-operating formations restrict separation of the panels to provide a pre-determined spacing between the side edges.

Preferably, the panel has a projection on one side edge and a rebate on the opposed side edge, one of the projection and rebate having a recess open towards one face of the panel and the other of the projection and rebate having a rib facing towards the other face of the panel.

9 & 10
could be
reversed

Other features, benefits and advantages of the invention in each of its aspects will be apparent from

the following description of exemplary embodiments with reference to the accompanying drawings wherein:-

Figure 1 is a perspective view from one side of a panel according to the present invention;

Figure 2 is a perspective view from the other side of the panel shown in Figure 1;

Figure 3 is a transverse section, to an enlarged scale of the panel shown in Figures 1 and 2;

~~Figure 4 is a transverse cross-section through a joint between two panels according to the present invention showing the panels in a first limit position with the side edges abutting;~~

~~Figure 5 is a transverse section similar to Figure 4 showing the panels in a second limit position with adjacent side edges slightly spaced apart;~~

Figure 6 is a ~~front~~ view of a door constructed from panels of the type shown in Figures 1 to 3;

Figure 7 is a rear view of the door shown in Figure 6; and

Figure 8 is a transverse section through the stiles and panels of the door shown in Figures 6 and 7.

Referring first to Figures 1 to 5 of the accompanying drawings, a wood panel 1 and a joint 2 between two similar panels 1,1' are shown and, in the following description, reference will be made to one or both panels as convenient for understanding of the invention in each of its aspects.

The panel 1 has parallel front and rear faces 3 and 4 respectively and is of uniform cross-section throughout its length.

Between the front and rear faces 3 and 4, the panel 1 has a longitudinal tongue 5 on one side edge and a longitudinal groove 6 on the opposed side edge

for reception of the tongue 5 of the adjoining panel 1' to form the joint 2.

The panel 1 further has a longitudinal projection 7 on the side edge between the groove 6 and the rear face 4 and a longitudinal rebate 8 on the opposed side edge between the tongue 5 and rear face 4 for reception of the projection 7 of the adjoining panel 1' when the tongue 5 is inserted into the groove 6.

The projection 7 has a longitudinal recess (9) of channel-section open towards the front face 3 of the panel 1 and the rebate 8 has a longitudinal rib (10) of convex profile facing towards the rear face 4 of the panel 1 for reception in the recess 9 of the adjoining panel 1' when the tongue 5 is inserted into the groove 6.

Above and below the tongue 5, offset upper and lower side edge faces 11a, 11b extend normal to the front and rear faces 3 and 4 and meet bevel faces 12a, 12b respectively at the front and rear faces 3 and 4.

Similarly, above and below the groove 6, offset upper and lower side edge faces 13a, 13b extend normal to the front and rear faces 3 and 4 and meet bevel faces 14a, 14b respectively at the front and rear faces 3 and 4.

The tip of the tongue 5 is provided on opposite sides with respective chamfer faces 15a, 15b such that the panel 1' can tilt relative to the panel 1 with the tongue 5 partially inserted into the groove 6 for locating the rib 10 in the recess 9.

Such location of the rib 10 in the recess 9 is effected automatically when the panels 1, 1' are pushed

tilt

together by engagement of the rib 10 with an inclined chamfer face 16 at the tip of the projection 7 which causes the panel 1' to tilt relative to the panel 1 assisted by the chamfer faces 15a,15b at the tip of the tongue 5.

pushing together
causes
automatic
tilt

The opposed side edges 17a,17b of the recess 9 are engaged by the rib 10 to limit the relative spacing of the adjoining side edges of the panels 1,1' as desired.

In a first limit position shown in Figure 4, the rib 10 engages the inner side edge 17a of the recess 9 when the tongue 5 is fully inserted into the groove 6 and the side edges of the panels 1,1' abut one another. In this position, the tip of the tongue 5 is slightly spaced from the base of the groove 6.

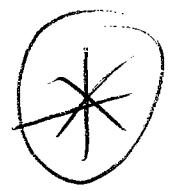

In a second limit position shown in Figure 5, the rib 10 engages the outer side edge 17b of the recess 9 when the tongue 5 is partially received in the groove 6 and the side edges of the panels 1,1' are spaced apart.

As will now be understood, the engagement of the rib 10 with the outer side edge 17b of the recess 9 restricts separation of the panels 1,1' and provides a positive indication to the user of a desired spacing between the side edges to allow for expansion of the panels 1,1' as may be caused if the panels 1,1' are exposed to moisture. In this way, assembly of adjoining panels 1,1' in a regular uniform manner with pre-determined spacing therebetween is facilitated.

A further benefit of such pre-determined location of the side edges of the panels 1,1' is that the tip of the tongue 5 is spaced from the base of the groove 6 thereby ensuring that expansion of the panels 1,1' does not result in transmission of forces tending to deform

the panels 1,1' through engagement between the tip of the tongue 5 and the base of the groove 6.

Additionally, by restricting separation of the panels 1,1' to control the spacing between the side edges, it is ensured that partial engagement of the tongue 5 in the groove 6 sufficient to resist deflection of the panels 1,1' is obtained.

In the embodiment above-described, the engagement of the rib 10 with the inner side edge 17a of the recess 9 corresponds to engagement of the upper and lower side edges faces of the adjoining panels 1,1' such that the bevel faces form V-shaped notches 18 where the front and rear faces of the panels meet each other.

Referring now to Figures 6 to 8, an external panel door 20 is shown comprising a plurality of vertical panels 21 having adjoining side edges connected by the joint 2 above-described with the panels 21 spaced apart as shown in Figure 8 to allow for expansion of the panels 21 without deforming.

The outer panels 21a,21b joined to stiles 22 are provided with the edge formation for forming the joint 2 on one side edge only, the other side edge being plain for reception in a longitudinal rebate 23 in the stile 21. The intermediate panels 21c are all similar to the panel 1 above-described having the edge formations for forming the joint 2 on both side edges.

The invention is not limited to the embodiments above-described. For example, the invented panel and joint thereby may be used in any application where controlled spacing of the panels is desired to allow for expansion of the panels such as flooring, cladding of walls or ceilings or even the construction of sheds or the like.

gate
surface
P. 1949e

flooring

The co-operating edge formations forming the joint may be of any suitable shape and configuration which provides a positive indication of a desired spacing between the side edges. For example, in certain applications, it may not be necessary to provide the panels with interlocking tongue and groove formations to resist deflection of the panels and a simple overlap joint may be provided between the adjoining side edges with the rib and recess being provided on opposed overlapping surfaces of the joint.

Each panel may have the cooperating formations on opposed side edges for assembly with similar panels as described. Alternatively, the panels may be of two types each having a respective one of the co-operating formations on both side edges.

The rib and recess may be replaced by any other suitable means for providing a positive indication of the relative positions of the adjoining side edges of the panels.

Although the invention has been described with reference to panels made of wood where the controlled spacing of the panels is of particular benefit, it will be understood that the panels may be made of other materials, for example laminates such as plywood, composites such as chipboard, or plastics such as PVC which can be extruded to any desired cross-section.

It will also be understood that the panels may be of any length, width or thickness having any pattern or decoration applied to or formed in the front and/or rear faces.

To prevent mis-assembly of the panels, the tongue and groove are offset towards the front face of each panel so that the front faces of adjoining panels are co-planar only when the panels are assembled in the correct orientation.

5075
H. H. H. H. H.

Claims:

1. A joint between adjoining side edges of two panels wherein the side edges have co-operating formations adapted to restrict separation of the panels to provide a pre-determined spacing between the side edges in the assembled joint.
2. A joint according to Claim 1 wherein the panels have front and rear faces and the co-operating formations are provided between the front and rear faces.
3. A joint according to Claim 1 or Claim 2 wherein the co-operating formations comprise a longitudinal recess on one panel that is open towards one of said faces and a longitudinal rib on the other panel that faces towards the other of said faces for reception in the recess in the assembled joint.
4. A joint according to Claim 3 wherein the rib is engageable with one side edge of the recess to restrict separation of the panels to provide the pre-determined spacing between the side edges of the panels in the assembled joint.
5. A joint according to Claim 4 wherein the rib is engageable with the opposed side edge of the recess when the side edges of the panel abut one another or to provide a pre-determined minimum spacing between the side edges of the panel in the assembled joint.
6. A joint according to any one of Claims 3 to 5 wherein one of the rib and recess is provided on a projection on the side edge of one panel and the other of the rib and recess is provided in a rebate on the side edge of the other panel in

which the projection is received in the assembled joint.

7. A joint according to any preceding Claim wherein a tongue is provided on the side edge of one panel for reception in a groove on the adjoining side edge of the other panel, and the tip of the tongue is preferably of reduced cross-section, for example the tip may have opposed chamfer faces.

8. A joint according to Claim 7 wherein adjacent side edge faces of the adjoining panels above the tongue and groove formations are laterally offset relative to the adjacent side edge faces below the tongue and groove formations.

9. The combination of first and second panels for assembly along adjoining side edges to form the joint according to any preceding Claim.

10. The combination according to Claim 9 wherein the first and second panels are similar having the co-operating formations on opposed side edges.

11. A panel having co-operating formations on the opposed side edges constructed and arranged such that when the panel is joined to a similar panel along adjoining side edges, the co-operating formations restrict separation of the panels to provide a pre-determined spacing between the side edges.

12. A panel according to Claim 11 wherein the panel has a projection on one side edge and a rebate on the opposed side edge, one of the projection and rebate having a recess open towards one face of the panel and the other of the projection and rebate having a rib facing towards the other face of the panel.

13. A panel according to Claim 12 having tongue and groove formations on the opposed side edges.

14. A panel according to Claim 13 wherein the tongue is on the rebate side edge and the groove is on the opposed projection side edge.

15. A panel according to Claim 14 wherein the recess is formed in a face of the projection between and substantially parallel to the front and rear faces of the panel.

16. A panel according to Claim 15 wherein said face is substantially coplanar with a sidewall of the groove.

17. A panel according to Claim 16 wherein the inner edge of the recess is aligned with a transverse abutment face on the side edge of the panel.

18. A panel according to any one of Claims 14 to 17 wherein the rib is formed on a face of the rebate between and substantially parallel to the front and rear faces of the panel.

19. A panel according to Claim 18 wherein said face is substantially co-planar with one side of the tongue.

20. A panel according to Claim 19 wherein the outer edge of the rib is aligned with a transverse abutment face on the side edge of the panel.

21. A door constructed from a plurality of panels having adjoining side edges connected by the joint according to any one of Claims 1 to 8.

22. Use of the combination according to Claim 9 or Claim 10 or a panel according to any one of Claims 11 to 20 in the construction of a door.

23. A joint between adjoining side edges of two panels substantially as hereinbefore described with reference to Figures 1 to 5 of the accompanying drawings.

24. A panel substantially as hereinbefore described with reference to Figures 1 to 5 of the accompanying drawings.

25. A door substantially as hereinbefore described with reference to Figures 6 to 9 of the accompanying drawing.

26. Any novel feature described herein and/or shown in the drawings.

Patents Act 1977
Examiner's report to the Comptroller under
Section 7 (The Search Report)

13

Application number
 9110787.0

Relevant Technical fields

(i) UK CI (Edition) F2M

(ii) Int CI (Edition) F16B

Databases (see over)

(i) UK Patent Office

(ii)
 Online Databases : WPI

Search Examiner

G HEMSLEY

Date of Search

28 JUNE 1991

Documents considered relevant following a search in respect of claims

1-25

Category (see over)	Identity of document and relevant passages	Relevant to claim(s)
X	GB 1430423 (GKN)	1-20
X	GB 1275511 (JEPPESSEN)	1-4
X, Y	GB 1237744 (LIMSTRA)	1-20
X	GB 1127915 (KAROSA) figure 7	1-20
X	US 3526420 (BRANCALEONE)	1-5, 9-13
X	EP 0248127 (HOCKNEY)	1-7, 9-13

SF2(p)

4MSAAX

16

Category	Identity of document and relevant passages	Relevant to claim(s)

Categories of documents

X: Document indicating lack of novelty or of inventive step.

Y: Document indicating lack of inventive step if combined with one or more other documents of the same category.

A: Document indicating technological background and/or state of the art.

P: Document published on or after the declared priority date but before the filing date of the present application.

E: Patent document published on or after, but with priority date earlier than, the filing date of the present application.

&: Member of the same patent family, corresponding document.

Databases: The UK Patent Office database comprises classified collections of GB, EP, WO and US patent specifications as outlined periodically in the Official Journal (Patents). The on-line databases considered for search are also listed periodically in the Official Journal (Patents).